



1120 North Main Street • Elkhart, IN 46514  
**PHONE:** 574•264•2131 **FAX:** 574•206•9713  
**INTERNET:** http://www.atwoodmobile.com

**HYDRAULIC**

**SURGE BRAKE SYSTEM**

**ENGLISH, FRANCAIS** (et Canada)

**•Installation •Operation •Maintenance**

Effective 11/21/07

**SAFETY ALERT SYMBOLS**

Safety Symbols alerting you to potential personal safety hazards. Obey all safety messages following these symbols.

**WARNING**  
 avoid possible injury or death

**CAUTION**  
 avoid possible injury and/or property damage

**FOR YOUR SAFETY**

**READ ALL INSTRUCTIONS BEFORE OPERATING BRAKE SYSTEM**

**Installer:** Provide this instruction to consumer.  
**Consumer:** Keep documents for future reference.

**INDEX**

**HYDRAULIC SURGE BRAKE SYSTEM**

Installation .....1-3  
 Straight Tongue .....1-2  
 A-Frame Weld-Between .....2  
 Painting the Brake Actuator .....2  
 Foundation Brakes .....2  
 Installation - Disc Brake Actuator/Solenoid Back-up Valve .....2-3  
 Bleed Brake System .....3

**OPERATION**

Towing .....3  
 Backing-up .....3-4

**MAINTENANCE** .....4  
 Extended Storage Instructions .....5

**WARRANTY** .....4  
 Troubleshooting .....5  
 Figures 1-15 .....6  
 Replacement Kits .....12

The installation instructions must be followed to insure safe operation of Atwood brake actuators and foundation brakes. Failure to install according to installation instructions nullifies warranty.

**DRUM BRAKE APPLICATIONS:**

- For best performance use Atwood Foundation Brakes with an Atwood Brake Actuator. These components are system matched.

**DISK BRAKE APPLICATIONS:**

- Use only Atwood 80360, 80366, 88740, 88730 Disc Brake Actuators for disc brake applications.
- Atwood Disc Brake Actuators have been tested for compatibility with Kodiak brand and Reliable brand Disc Brake Systems.
- To be used with a maximum of 4 2-1/4" diameter calipers.
- For more information call Atwood Mobile Products (866-869-3118), Kodiak Trailer Components (817-284-2324), or Reliable Tool & Machine (219-347-4000).

**WARNING**  
**PERSONAL INJURY & PRODUCT DAMAGE**

- Observe maximum trailer weight for Atwood brake actuator Gross Vehicle Weight Rating (GVWR) and tongue load.
- Do not exceed these capacities. Gross Vehicle Weight Rating is total weight of trailer fully loaded included personal belongings. Know your trailer GVWR.

**CAUTION**  
**PRODUCT DAMAGE / BRAKE FAILURE**

- Use only a 2" machined or forged ball with Atwood brake actuator. Ball capacity must be equal to or greater than trailer GVWR. Do not use a worn hitch ball-it is unsafe and must be replaced.
- Do not submerge actuator in water. Water may enter and corrode master cylinder, contaminating Brake System, causing brake failure.

**INSTALLATION**

**WARNING**  
**BRAKE FAILURE**

- Brake actuator **MUST** BE installed with frame stops in contact with trailer tongue.

**STRAIGHT TONGUE - BOLT ON APPLICATION (FIG 1)**

**8000 LB. BRAKE ACTUATORS** SAE CLASS 4 - DISC AND DRUM APPLICATIONS  
**8000 LB. GVWR, MAX. TONGUE LOAD 1000 LB. - DO NOT EXCEED THESE RATINGS**

**PART NO. 83005, 83010 - DRUM APPLICATION / PART NO. 80366 - DISC APPLICATION**

1. Determine proper location of brake actuator on trailer tongue. Set actuator on trailer tongue, push down and back until frame stops (FIG 1-A), making contact with tongue.
2. Drill 17/32" holes in trailer tongue where bolt holes are positioned.
3. Reinforcement of trailer tongue spacer must be 1/2" ID pipe or equiv. (FIG 3-A).
4. Attach brake actuator to trailer tongue with 1/2" diameter bolts (3) S.A.E. grade 8 lockwasher (3) and nuts (3) (FIG 1-B). Torque nuts to 110-120 ft/ lbs.

**6000 LB. BRAKE ACTUATORS** SAE CLASS 4 - DISC AND DRUM APPLICATIONS

**6000 LB. GVWR, MAX. TONGUE LOAD 900 LB. - DO NOT EXCEED THESE RATINGS**

**PART NO. 82543, 83153, 83154, 84132, 88730, 88740**

1. Determine proper location of brake actuator on trailer tongue. Set actuator on trailer tongue, push down and back until the frame stops (FIG 1-A), making contact with tongue.
2. Drill 17/32" holes in trailer tongue where bolt holes are positioned.
3. Reinforcement of trailer tongue spacer must be 1/2" ID pipe or equiv. (FIG 3-A).
4. Attach brake actuator to trailer tongue with 1/2" diameter bolts (2) S.A.E. grade 5 or greater lockwasher (2) and nuts (2) (FIG 1-B). Torque nuts to 70-80 ft. lbs.

**WARNING**  
**BRAKE FAILURE**

- Trailer tongue must have adequate strength to support attachment of brake actuator without mounting nuts losing torque during life of trailer.
- Trailer tongue must be properly reinforced to prevent any potential loosening of brake actuator during service.

**STRAIGHT TONGUE - WELD ON APPLICATION (FIG 2)**

**WELDING INSTRUCTIONS**

- **M.I.G. OR STICK** - 5/32" fillet weld minimum.
- **M.I.G. WELDING** - Use A.W.S. ER 70S-3 or 6 wire or equivalent with a diameter of .035 - .045. The recommended shielding gas mixture is 75% - 95% Argon & 25% - 5% CO<sub>2</sub>.
- **STICK WELDING** - Use E6011 A.W.S. welding rod or equivalent. Recommended machine settings for specific electrode diameter are as follows: 1/8" electrode set power between 115-130 Amps DC or 5/32" electrode set power between 140-160 Amps DC.

**8000 LB. BRAKE ACTUATORS** SAE CLASS 4

**8000 LB. GVWR, MAX. TONGUE LOAD 1000 LB. - DO NOT EXCEED THESE RATINGS**

**PART NO. 83000 - DRUM APPLICATION / PART NO. 80360 - DISC APPLICATION**

1. Determine proper location of brake actuator on trailer tongue. Set actuator on trailer tongue, push down and back until frame stops (FIG 2-A), making contact with tongue.
2. Using **WELDING INSTRUCTIONS** weld actuator to trailer with a minimum of 9" weld per side. Make a 5/32" fillet weld (FIG 2-B).
3. Make sure to return weld on front end of frame of trailer up inside actuator frame to forward frame stop (see FIG 2-C).

**6000 LB. BRAKE ACTUATORS SAE CLASS 4 - DISC AND DRUM APPLICATIONS****6000 LB. GVWR, MAX. TONGUE LOAD 900 LB. - DO NOT EXCEED THESE RATINGS****PART NO. 82543, 83153, 83154 - DRUM APPLICATION ONLY****PART NO. 88740 - DISC APPLICATION ONLY**

1. Determine proper location of brake actuator on trailer tongue. Set actuator on trailer tongue, push down and back until frame stops (FIG 2-A), making contact with tongue.
2. Using **WELDING INSTRUCTIONS** weld actuator to trailer with a minimum of 7" weld per side. Make a 5/32" fillet weld (see FIG 2-B).
3. Make sure to return weld on front end of frame of trailer up inside actuator frame to forward frame stop.

**CAUTION  
DAMAGE TO CABLE**

- Breakaway cable and hook must not touch ground during welding operation.

**A-FRAME - WELD-BETWEEN APPLICATION (FIG 4)****8000 LB. BRAKE ACTUATORS SAE CLASS 4 - DISC AND DRUM APPLICATIONS****8000 LB. GVWR, MAX. TONGUE LOAD 1000 LB. - DO NOT EXCEED THESE RATINGS****PART NO. 83000 - DRUM APPLICATION / PART NO. 80360 - DISC APPLICATION**

1. Position actuator between A-Frame members with leading edge of A-Frame located 8" from back of actuator (FIG 4).
2. Using **WELDING INSTRUCTIONS** weld actuator to trailer tongue by welding along entire length where trailer frame contacts actuator. Weld must be a minimum of 9" along each side (FIG 4).

**6000 LB. BRAKE ACTUATORS SAE CLASS 4 - DISC AND DRUM APPLICATIONS****6000 LB. GVWR, MAX. TONGUE LOAD 900 LB. - DO NOT EXCEED THESE RATINGS****PART NO. 82543, 83153, 83154 - DRUM APPLICATION ONLY****PART NO. 88740 - DISC APPLICATION ONLY**

1. Position actuator between A-Frame members with leading edge of A-Frame located 5" from back of actuator (FIG 4).
2. Using **WELDING INSTRUCTIONS** weld actuator to trailer tongue by welding along entire length where trailer frame contacts actuator. Weld must be a minimum of 7" along each side (FIG 4).

**CAUTION  
PRODUCT DAMAGE**

- Breakaway cable and hook must not touch ground during welding operation.
- Weld trailer A-frame members together with additional bracing (i.e. cross members or jack mounting plates (FIG 4). Brake actuator alone is not designed to withstand torsional twist of trailer.
- Cross member(s) should be comparable in strength to trailer frame, and located as close to brake actuator as possible.

NOTE: If Atwood top and bottom jack mounting plates are used (MPD 82570 or MPD 80255) (FIG 4-A), move jack mounting plates as close to brake actuator as possible and weld along entire area where plates and trailer frame contact. Use **WELDING INSTRUCTIONS**.

**PAINTING THE BRAKE ACTUATOR****DIP PAINTING PROCEDURE**

NOTE: Carefully perform procedure in order given.

1. Plug vent hole in master cylinder boot.
2. Fully apply brake actuator.
3. Plug master cylinder outlet port (1/8" NPTF thread).
4. Plug master cylinder reservoir port to prevent paint from entering master cylinder.
5. Paint brake actuator.
6. Remove all plugs and fully release brake actuator.
7. Inspect for paint contamination of master cylinder and shock absorber shaft after painting. Replace parts if contaminated with paint.
8. Continue with **MANDATORY FUNCTIONAL CHECK AFTER PAINTING**.

**SPRAY PAINTING PROCEDURES**

1. Fully apply brake actuator.
2. Plug master cylinder outlet port (1/8" NPTF thread).
3. Plug master cylinder reservoir port preventing paint from entering master cylinder.
4. Paint brake actuator.
5. Fully release brake actuator & paint unpainted portions of socket assembly.
6. Remove all plugs.
7. Inspect for paint contamination of master cylinder and shock absorber shaft after painting. Replace parts if contaminated with paint.

**MANDATORY FUNCTIONAL CHECK AFTER PAINTING**

1. Check function of ball socket and latching mechanism by inserting, locking and removing a 2" diameter hitch ball. Once hitch ball is fully inserted in socket, release handle must close completely and freely when released.
2. If ball socket and latching mechanism does not close completely and freely as described above.
  - a. Check for paint build-up in ball socket and clean if necessary.
  - b. Lubricate ball socket and latching mechanism with SAE 30 oil and work mechanism by inserting, locking and removing a 2" diameter hitch ball until latching mechanism does work freely.
3. Move back-up lever to indicated back-up position and lock. Operate brake actuator back-up lever, return to towing position freely using only return spring force. Clean off excess paint and lubricate as necessary to ensure lever assembly operates freely.

**CAUTION  
TRAILER COULD DISCONNECT**

- DO NOT use actuator if latching mechanism does not operate freely. Contact Atwood Service Department at 866-869-3118.

**FOUNDATION BRAKES (FIG 5-8)**

SIZE	RATED AXLE CAPACITY LBS.
7"x1-3/4"	1800 lbs. (2500 lb. axle capacity when used with an integral cast hub and drum)
10"x2-1/4"	3500 lbs.
12"x2-1/4"	6000 lbs.

1. Check if axle has brake flanges (FIG 5-A) if so, skip step No. 2.
  2. If axle does not have brake flanges, install flanges as follows:
    - a. Secure flange to back of brake assembly (FIG 5-B) with 4 bolts (FIG 5-C).
    - b. Insert brake assembly into hub and drum assembly (FIG 5-D). Drum must completely cover surface of brake shoes (FIG 6). Be certain brake assembly back plate does not contact drum edge (FIG 6-A), and inside edges of shoes are not in contact with hub or drum.
    - c. Adjust brake shoes snugly against drum by inserting brake adjusting tool (FIG 7-A & B) through adjusting slot (FIG 7-C). Back plate must be centered within drum diameter after adjustment. Visually check for equal space between edge of back plate and edge of drum.
    - d. Mount brake/drum/flange assembly on spindle and secure with spindle nut. Be sure brake/drum/flange assembly is fully mounted on spindle.
    - e. With trailer level, locate top of brake flange parallel with bottom of trailer frame (FIG 8).
    - f. Tack weld flange to axle (a tack weld is a small semipermanent weld used for securing).
    - g. Remove brake/drum assembly.
    - h. Finish welding flange securely to axle, using **WELDING INSTRUCTIONS**.
  3. Mount brake and shoe assembly to flange. Wheel cylinder must be at top of brake with rubber boot toward the front of trailer. For 7" brakes use nuts and lockwashers provided (torque to 50 ft. lbs.).
  4. Mount drum and bearings on axle spindle, secure with washer and spindle nut.
  5. Tighten spindle nut securely and then loosen (or untighten) nut one quarter (1/4) turn 90°.
  6. Consult installation instructions to connect brake piping MPD 85869.
- NOTE: Consult Atwood Engineering Dept. when using non-Atwood brake piping or other components or when questions arise concerning installation or application.
7. Raise one trailer wheel at a time, remove dust clip from adjusting slot at lower part of back side of brake assembly and insert brake adjusting tool (FIG 7). Adjust brake shoes out by moving end of adjusting tool as illustrated, only until adjustment wheel (FIG 7-D) will not turn. When this condition is felt by rotating wheel, back-off (loosen) adjustment until wheel will just turn freely.

**INSTALLATION - DISC BRAKE ACTUATOR SOLENOID BACK-UP VALVE****WARNING  
DEATH OR PERSONAL INJURY**

- This system requires the solenoid wire leads be connected ONLY into the tow vehicle back-up light circuit.

**8,000 LB. ACTUATORS** are equipped with a solenoid back-up valve.

1. Connect the solenoid valve wire leads to the tow vehicle back-up light circuit.
2. Connect trailer brake line to actuator.
3. Bleed brake system.

**6,000 LB. ACTUATORS** are not equipped with a solenoid back-up valve. When a solenoid back-up valve is desired please contact Atwood for the solenoid back-up valve kit. Atwood Mobile Products 866-869-3118.

To install Atwood solenoid back-up valve -

1. Remove the plug in return port of master cylinder (this is the upper port in the master cylinder).
2. Install straight barbed fitting (torque to 16-20 in/lb).
3. Install assembly in supply port of master cylinder (this is the lower port in the master cylinder).
4. Connect the solenoid wire leads only into the reverse back-up light circuit.
5. Connect trailer brake line to actuator.
6. Bleed brake system

#### FOR DISC BRAKE SYSTEMS

 **CAUTION**  
**DAMAGE TO BRAKE ACTUATOR OR VEHICLE**

- If brass orifice fitting is not installed (FIG 10B), trailer-braking action may cause vehicle(s) to shake during brake applications.

The brass orifice fitting installed in master cylinder (FIG 10A) of brake actuator assembly must remain in hydraulic circuit to brakes (FIG 10C) of trailer.

If brass orifice fitting must be moved to accommodate plumbing (FIG 10E) for a back up solenoid valve (FIG 10D), it must be replaced in hydraulic circuit in line to brakes.

 **WARNING**  
**DEATH OR PERSONAL INJURY**

- Contaminated brake fluid in system could plug brass orifice fitting. This could render brakes inoperative.

Be especially careful to clean all fittings, tubing and threads between master cylinder and brass orifice fitting. A very small particle of dirt or thread sealant can plug hole in orifice.

- Do not use Teflon® tape on fittings.
- If a liquid or paste thread sealant is used, keep it back two threads from end of male fitting.
- Do not apply sealant to female threads. Clean female threads thoroughly.

#### BLEED BRAKE SYSTEM

 **CAUTION**  
**BRAKE FAILURE**

- DO NOT use brake fluid drained from brake system in refilling master cylinder. Brake fluid can be contaminated from the system.

1. Remove master cylinder filler cap and fill reservoir with DOT type 3 or 4 automotive brake fluid.
2. Check all hydraulic line fittings & connections to make sure they are leak free.
3. At brake assembly, connect a bleeder hose to bleeder fitting on wheel cylinder and submerge free end in a container with brake fluid. DO NOT reuse brake fluid.

NOTE: Use power bleeder or bar with 2" diameter hitch ball attached (FIG 9).

Do not use breakaway cable for purpose of bleeding brake system. If a power bleeder is used air pressure 35 PSI is most effective.

NOTE: Bleed brakes on rear most axle furthest from the actuator first.

4. Loosen bleeder fitting at top of brake assembly.
5. Apply actuator (see FIG 9) and tighten bleeder fitting. Return actuator to forward position. Again, loosen bleeder valve one turn and apply actuator. Repeat this procedure until fluid expelled from bleeder hose is free of air bubbles. It is helpful to lower the trailer tongue to promote air bubble movement in the brake tubing. It is also helpful to tap gently along the brake tubing during brake bleeding to keep air bubbles from sticking to the inside of the brake tubing. During this procedure, master cylinder reservoir fluid level must be maintained at no less than 1/2 full and no more than 1/2" from top of reservoir.
6. When no air bubbles are visible, close bleeder valve securely and remove bleeder hose.
7. Repeat STEP 1-6 for remaining brake, then brakes on forward axle.
8. If installation is tandem axle with brakes on both axle, repeat bleeding procedure on rear axle brakes for second time to assure positive purging of all air in system.
9. After bleeding has been completed, re-check fluid level in master cylinder.

#### OPERATION - TOWING

 **CAUTION**  
**TRAILER MAY DISCONNECT**

- Release handle (FIG 12A) must be fully closed before towing.
- Do not force release handle into closed position.

1. Position actuator ball socket above 2" ball.

NOTE: Do not damage actuator when backing up towing vehicle for hook-up.

2. Hold release handle in open position (FIG 11A). Release handle must be held in fully open position to remove from or place on ball.
3. Lower trailer tongue until ball rests in ball socket.
4. Close release handle (FIG 12A). Release handle will close freely with finger pressure when ball is properly inserted into ball socket.
5. To make sure actuator is securely latched onto ball, extend trailer tongue jack to ground and lift car and trailer combination 2" to 4". If ball does not disengage, actuator is securely attached.
6. Insert padlock or bolt through lock hole for theft protection.
7. Connect breakaway cable solidly to bumper or frame of tow vehicle as near to center as possible. Cable must hang clear of trailer tongue and long enough to permit short radius turns without pulling breakaway cable forward.
8. Make sure breakaway cable (FIG 13C) is in released position with indicator bead (FIG 13B) touching or resting against cable spring stop (FIG 13A).

 **CAUTION**  
**PRODUCT DAMAGE**

- DO NOT use breakaway cable as a parking brake.

NOTE: Check location of breakaway cable periodically during each trip, indicator should rest against spring stop. Accidental application will cause brakes to drag and heat up, causing failure.

9. Cross safety chains under tongue & securely attach to bumper or frame of tow vehicle.

 **CAUTION**  
**TRAILER DAMAGE**

- Safety chains must be used.

10. Retract jack fully. Remove and store caster, if applicable.
11. Check for proper car-trailer hook-up: tow vehicle and trailer should be level with positive tongue load. For further information, consult a dealer or Atwood Service Department.
12. Back-up lever knob must be positioned in **TOWING POSITION** (FIG 15-A).
13. If actuator is used with equalizing hitch, be sure hanger chains (FIG 14D) hang between straight down and forward up to 34° (FIG 14C). DO NOT use less than 6-1/2" hanger chain length (FIG 14X). For optimum brake performance, hang chains forward 34° (FIG 14).
14. DO NOT use Atwood brake actuator with a sway controller, unless prior Atwood Engineering approval of sway control system has been received.
15. You are now ready to tow your vehicle.

 **CAUTION**  
**PRODUCT & TRAILER DAMAGE**

- Avoid sharp turns. This could bend, create extreme stress or fracture either actuator or trailer tongue.

#### BACKING UP

1. Follow step 1 through 15 for **TOWING**.
2. If equipped with solenoid valves skip to STEP 5.
3. Before backing up a slope or through soft ground, pull trailer forward slightly to assure actuator socket is in fully forward position.
4. Move lever knob on side of actuator downward from **TOWING POSITION** (FIG 15A) along curved slot in actuator frame to **BACK-UP POSITION** (FIG 15B). Slot has a notch at bottom of its travel. Push lever knob down to engage locking notch.
5. Back trailer up.

 **CAUTION**  
**PRODUCT & TRAILER DAMAGE**

- Avoid sharp turns. This could bend, create extreme stress or fracture either actuator or trailer tongue.

6. If trailer is to be uncoupled from tow vehicle after backing with lever knob engaged, block all trailer wheels and pull forward slightly to take strain off actuator. Uncouple actuator by lifting release handle and raising trailer tongue. Make sure lever knob is in **TOWING POSITION** (FIG 15A) when uncoupling from trailer.

**⚠ CAUTION  
PRODUCT & TRAILER DAMAGE**

- Before towing trailer, lever knob must be disengaged and in **TOWING POSITION**.

**MAINTENANCE**

1. Keep all links and pivots lubricated to prevent rusting and ensure ease of operation. Use SAE 30 oil, lubricate inside release handle and inside actuator body reached from underside of actuator.

NOTE: Lubricate hitch ball with conventional automotive grease or a lubricant made for hitch balls.

2. Check for leaks in brake system. Periodic checks should be made on all hoses and fittings to guard against cuts and worn hoses which may cause failure (leaks, rupturing under pressure, and collapsing). Replace defective hoses.
3. Check brake fluid level in master cylinder reservoir. Keep filled to within 1/2" from top of reservoir. Use only DOT Type 3 or 4 brake fluid. Check electrical connections on reverse solenoid if system has one. Electrical connections should be sound and free of corrosion. Check reverse solenoid function.

**⚠ CAUTION  
BRAKE FAILURE**

- DO NOT fill master cylinder reservoir with used brake fluid.
- DO NOT fill reservoir beyond 1/2" from top.
- DO NOT overfill, brake fluid will damage paint.
- DO NOT use silicone type brake fluid.
- Yearly inspect brakes for excessive wear, replace lining if necessary.

**Atwood Hardware Systems & Components Limited Warranty**

Atwood Mobile Products warrants to the original owner this product will be free of defects in material and workmanship for a period of two years from the date of purchase. Atwood's liability hereunder is limited to the replacement of product, repair of product or replacement of product with a reconditioned product, at the discretion of the manufacturer. The warranty is void if the product has been damaged by accident, unreasonable use, neglect, tampering or other causes not arising from defects in material workmanship. The warranty extends to the original consumer purchaser of the product only, and is subject to the following conditions:

1. For two (2) year commencing with the date of purchase, Atwood will replace or repair any Hardware System & Components that are found to be defective by Atwood in material or workmanship.
2. In the event of a warranty claim, the Original Purchaser must contact the Atwood Consumer Service Department, 1120 North Main St., Elkhart, IN 46514, Telephone: 866-869-3118 Fax: 574-206-9655. Warranty claim service must be performed as approved by the Atwood Consumer Service Department. Warranty replacement hardware systems and components or parts will be furnished freight prepaid. Labor cost to repair or replace will be limited to the amount of the original purchase price of the systems and components. The replaced warranty products or parts become the property of Atwood Mobile Products and must be returned to the Atwood Consumer Service Department freight prepaid, unless prior arrangements have been made.
3. This limited warranty is valid only when the product is applied, installed, maintained and operated in accordance with this Atwood Installation, Maintenance and Operating Manual (MPD 87984). Any deviation from these recommended specifications must be approved in writing by Atwood.
4. Any implied warranties are limited to the duration of this limited warranty as stated above. Atwood does not assume responsibility for consequential damage or loss, including loss of use of vehicle, loss of time, inconvenience, expense for gasoline, telephone, travel, lodging, loss or damage to personal properties, or loss of revenues. Some states do not allow limitations on how long an implied warranty lasts or limitations on consequential damages, so the above limitations may not apply to you. This limited warranty gives you specific legal rights which may vary from state to state.

4. Flush system yearly or when system is known to be contaminated. For Disc Brake Systems remove orifice fitting (FIG 10) before flushing. Check fitting orifice to make sure it is clear. The orifice is .015" DIA it may be replaced if it is plugged with Atwood P/N # MPD 80777. The orifice fitting must be replaced after flushing the system.

NOTE: Wheel bearing and seals should be inspected and packed at this time.

**ADJUSTING 7", 10" & 12" DRUM BRAKES**

Trailer brakes should be adjusted after the first 1,000 miles of use and at least every 2,000 miles of use thereafter. In addition, trailer brakes should also be inspected for excessive wear, replace lining if necessary and adjusted at the beginning of each season or yearly. Wheel bearings and seals should be inspected and packed at this time.

Raise one trailer wheel at a time, chock opposite wheel to prevent trailer from rolling. Remove dust clip from adjusting slot at lower part of back side of brake assembly and insert brake adjusting tool. Adjust brake shoes out until wheels will not turn by moving end of adjusting tool toward top of brake. When this condition is felt, by rotating wheel, back-off (loosening) adjustment until wheel will just turn freely.

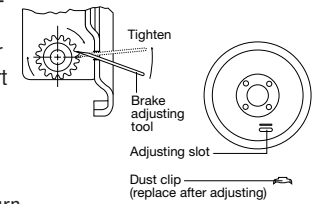

## TROUBLE SHOOTING GUIDE

Guides are only intended for use on Atwood® products by service technicians who have successfully completed Atwood® training. This guide should be used in conjunction with appropriate Instruction Manual provided with the product and any applicable Industry Standards. This is not intended to be a complete list. Please direct questions concerning service of Atwood® products to 866-869-3118 before proceeding.



### WARNING

#### PERSONAL INJURY AND/OR PRODUCT DAMAGE

• If any of the following conditions develop, trailer must not be used until proper corrective action is taken.

### SQUEAKING, CLATTER OR CHUCKING

CONDITION	SOLUTION
LACK OF HITCH BALL LUBRICATION	Lubricate with conventional automotive grease or commercial lubricant made for hitch balls
<b>BINDING LINKAGE &amp; PIVOTS ON</b>	
BRAKE ACTUATOR	Oil linkage & pivots on brake actuator
LOOSE HITCH BALL	Inspect hitch & tighten
LOOSE HITCH	Inspect hitch & tighten
ACTUATOR LOOSE ON TRAILER FRAME	Inspect brake actuator & tighten
HITCH BALL WORN OR TOO SMALL	Replace
OVERHEATED BRAKES	Replace wheel bearing
BROKEN BRAKE DRUM(S)	Replace brake drum(s) & check brake shoes
LOW BRAKE FLUID LEVEL	Fill & bleed brakes, per IOM instructions
WORN OUT SHOCK ABSORBER	Replace
PARTIAL APPLICATION OF BREAKAWAY CABLE	Fully release breakaway cable
BRAKES IMPROPERLY ADJUSTED	Check brakes for adjustments per IOM instructions
BROKEN BRAKE RETURN SPRING	Replace return spring
SEIZED ACTUATOR MASTER CYLINDER	Replace/rebuild actuator master cylinder
WORN OUT BRAKE SHOES	Replace brake shoes and check brake drums
LEAKY WHEEL CYLINDER	Replace/rebuild wheel cylinders and replace brake shoes. Clean drums and other hardware

### RELEASE HANDLE DOES NOT CLOSE EASILY

CONDITION	SOLUTION
OVERSIZED BALL	Check ball size
BALL NOT FULLY INSERTED INTO SOCKET	Check for proper ball size. Check to see if tongue jack is fully retracted. Hold release handle open when inserting ball.
FOREIGN MATERIAL IN ACTUATOR SOCKET	Clean and lubricate

### BRAKE OVERHEATING, SIDE PULL, BRAKES DO NOT OPERATE, POOR BRAKE PERFORMANCE

CONDITION	SOLUTION
ONLY ONE BRAKE IS APPLYING	Check brake adjustment per IOM instructions.
LEAKING WHEEL CYLINDER	Check and replace wheel cylinder and bleed brakes per IOM instructions.
SEIZED WHEEL CYLINDER PISTON	Check and rebuild/replace wheel cylinder and bleed system per IOM instructions.
FOREIGN MATERIAL IN BRAKE UNIT	Clean thoroughly
LOW HYDRAULIC FLUID LEVEL	Fill and bleed brakes, per IOM instructions
A BENT SHOULDER BOLT	Replace
A BEND PUSH ROD IN THE SHOCK ABSORBER	Replace shock absorber
A DAMAGED SOCKET ASSEMBLY	Replace actuator
BROKEN/PINCHED BRAKE LINES	Replace
BRAKE ACTUATOR FRAME DAMAGED	Replace actuator
WORN BRAKE SHOE(S)	Replace brake shoe(s)

### TOWING VEHICLE SHAKING BACK AND FORTH

CONDITION	SOLUTION
WORN VEHICLE SUSPENSION	Replace shock absorber
HITCH NOT SECURE	Tighten all bolts and nuts
UNDER-SIZED HITCH BALL	Ball should be 2" machined/forged type

## EXTENDED STORAGE INSTRUCTIONS

- Preventative maintenance is recommended for extended periods of storage.
1. Check brake system for proper fluid level in master cylinder, bleed all lines.
  2. Lubricate all links and pivots to prevent any rusting.
  3. Remove wheel and drum assemblies and spray a good anti-corrosion compound (CRC formula 5-56) under rubber boot on forward end of brake wheel cylinder. Avoid spraying drum and brake lining.
  4. Grease all bearings and reinstall wheel and drum assemblies.
  5. Make sure breakaway cable is fully released.
  6. After extended storage refer to **MAINTENANCE** Steps 1 through 5, to insure trailer readiness for towing.
  7. Adjust drum brakes

### PROPER TOWING CHECKLIST

- ✓ Inspect brake fittings for leaks.
- ✓ Adjust brakes every 2000 miles.
- ✓ Lubricate all mechanical moving parts.
- ✓ Inspect the breakaway cable for any kinks.
- ✓ Verify a one-piece 2" ball is used, without chips, dirt or hairline cracks.
- ✓ Securely attach safety chains to trailer and tow vehicle.
- ✓ For proper braking, trailer should set level when attached to tow vehicle to produce a positive tongue load.
- ✓ DOT 3 or DOT 4 brake fluid should be used in master cylinder and fill it from 1/2 full to 1/2" from top of cylinder reservoir.

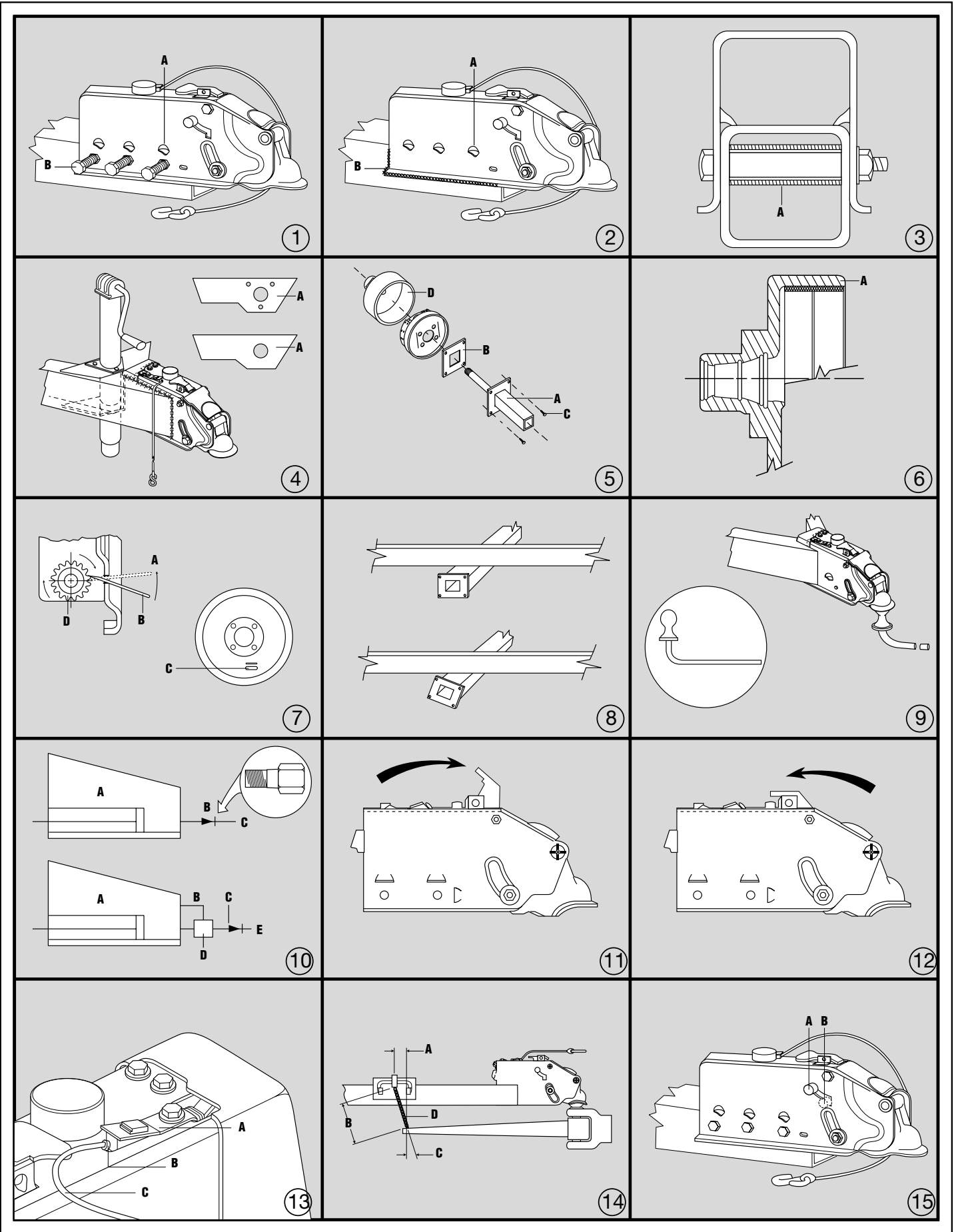

# ATWOOD UNI-SERVO BRAKES

## 7" BRAKES

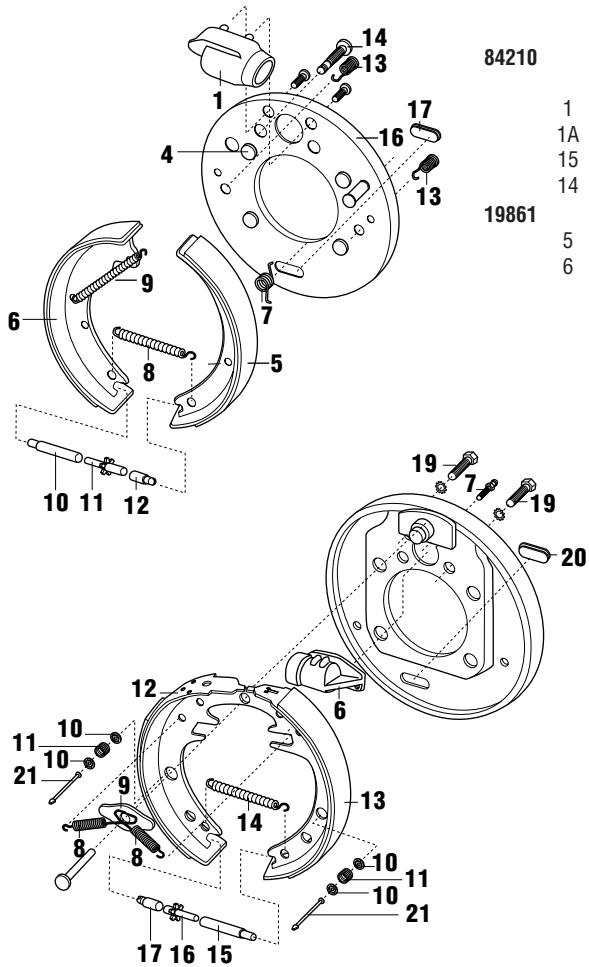

- 84210 NEW STYLE Wheel Cylinder Kit (one axle only) 23400**
- 1 (1) WHEEL CYLINDER, R.H.
  - 1A (1) WHEEL CYLINDER, L.H.
  - 15 (4) 5/16" - 18 x 3/4" CAP SCREW
  - 14 (2) 5/16" - 18 FLAT HEAD SCREW
- 19861 Shoe & Lining Kit (one axle) 18191 23401**
- 5 (2) PRIMARY SHOES WITH LINING
  - 6 (2) SECONDARY SHOES WITH LINING

- Spring Kit (one axle)**
- 8 (2) ADJUSTING SCREW SPRINGS
  - 9 (2) SECONDARY RETRACTOR SPRINGS
  - 7 (1) TORSION SPRING R.H.
  - 7A (1) TORSION SPRING L.H.
  - 13 (4) SHOE HOLD DOWN SPRINGS
- 18191 17 Dust Clip 23401 Adjusting Screw, Pivot Socket & Nut Assembly**
- 10 (1) NUT
  - 12 (1) PIVOT SOCKET
  - 11 (1) ADJUSTING SCREW

## 10" BRAKES

- 21669 Wheel Cylinder Replacement Kit (1 axle) 19862 Brake Shoe and Lining Kit (1 axle) 23385 Brake Shoe Spring & Hold Down Kit (1 axle)**
- 6 (1) WHEEL CYLINDER, R.H.
  - 6 (1) WHEEL CYLINDER, L.H.
  - 19 (4) 5/16" - 8 x 1/2" MOUNTING SCREWS
  - 12 (2) PRIMARY SHOES WITH LINING
  - 13 (2) SECONDARY SHOES WITH LINING
  - 8 (4) PRIMARY AND SECONDARY RETRACTOR SPRINGS

- 14 (2) ADJUSTING SCREW SPRINGS 21 (4) SHOE HOLD DOWN PINS 11 (4) SHOE HOLD DOWN SPRINGS 10 (8) SHOE HOLD DOWN WASHERS 18499 9 (2) Shoe Guide Plate 23401 Adjusting Screw, Pivot Socket & Nut Assembly 15 & 16 (1) NUT AND SCREW 17 (1) PIVOT SOCKET 18191 20 (2) Dust Clip 7 (2) Bleeder Nut - not available separately**

## HYDRAULIC BRAKE ACTUATORS

**TO ORDER:** All kits available for field replacement are numbered. Parts illustrated but not numbered are not available for replacement. Contact the Service Department for further information.

**NOTE:** Save all attaching hardware when disassembling.

KIT #	DESCRIPTION	REPLACEMENT KIT INCLUDES
85830	SHOCK ABSORBER	4, 24-2 EA. 28-2 EA. 29-2 EA.
87478	CAP	15
85842	SHOULDER BOLT	20, 21, 24-2 EA., 25, 26, 27
85844	RELEASE HANDLE	5, 13, 18, 22, 24-3 EA., 30
85849	STOP & SPRING ASSEMBLY	9, 11, 14, 24
85852	PUSH ROD ASSEMBLY	3, 7, 11, 14-5 EA., 16, 17, 24-2 EA., 34, 8, 9
84258	BOOT	8
80777	ORIFICE-DISC BRAKE APPLICATIONS ONLY	31
85837	MASTER CYLINDER-PUSH ROD KIT DRUM BRAKE APPLICATION	3, 6, 7, 8, 9, 11, 14-5 EA., 16, 17, 24-2 EA. 34
85841	MASTER CYLINDER DRUM BRAKE APPLICATION	6, 7, 14-4 EA. MUST ORDER 84258 SEPARATELY
85838	MASTER CYLINDER-PUSH ROD KIT DISC BRAKE APPLICATION	3, 6, 7, 8, 9, 11, 14-5 EA., 16, 17, 24-2 EA. 34, 15
85840	MASTER CYLINDER DISC BRAKE APPLICATION	6, 7, 14-4 EA. MUST ORDER 84258 SEPARATELY
80376	SOLENOID KIT (DISC ONLY)	CYLINDER, GASKET, SCREW BACK UP SOLENOID ASSEMBLY
85271	6,000 LB DRUM BRAKE HOUSING KIT	7, 35, 36
85309	6,000 LB HOUSING KIT - DISC BRAKES	7, 35, 36

