



LEVELEGS™ w/SENSOR TECHNOLOGY
FOR TOWABLE RV'S
Installation • Operation • Maintenance

ENGLISH

Effective 8/8/11
 Rev B

Table of Contents

Installation	2-10
Leveler legs.....	2
Controller.....	4
Dip-switch Configurations.....	5
Wire Harness Installation.....	7
Operation	11-14
Program HOME Position.....	12
Program/Reprogram AUTO Level Position / Keypad Function.....	13
Unhooking from Tow Vehicle & Leveling/Hooking to Tow Vehicle...	14
Leveling Features.....	15
System Protection Features.....	16
Maintenance / Warranty.....	17
Troubleshooting	18-21
Index.....	22

SAFETY ALERT SYMBOLS	
Safety Symbols alerting you to potential personal safety hazards. Obey all safety messages following these symbols.	
 WARNING avoid possible injury or death	 CAUTION avoid possible injury and/or property damage

FOR YOUR SAFETY READ ALL INSTRUCTIONS BEFORE INSTALLATION AND OPERATION

Installer: Provide these instructions to the consumer.
Consumer: Keep documents for future reference.
 Atwood Levelers™ Levelers are intended for use on recreation vehicle motorhomes and trailers, any other use is strictly prohibited.

 WARNING RV CAN MOVE OR COLLAPSE
<ul style="list-style-type: none"> • Never exceed the rated capacity of the leveler as stated on its label. • Levelers are not designed to be used as jacks. Do not use levelers to lift the vehicle during tire changes, axle work or other servicing. <p style="text-align: center;">The tires must stay on the ground.</p>

INSTALLATION

LEVELER LEGS

1. Install direct drive levelers as close to the front bulkhead, and the rear levelers as close to the rear wheels as possible in a rectangular formation. If the levelers are installed unevenly, the effectiveness of the system will be compromised.

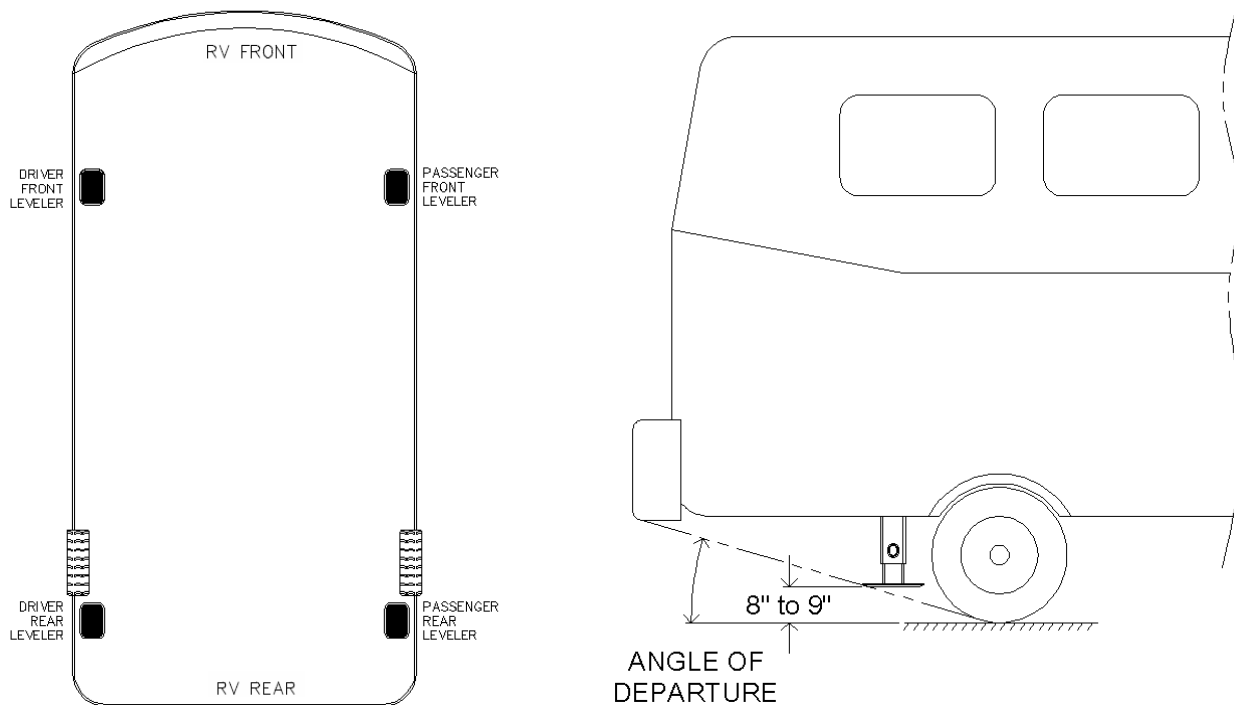

2. Position leveler vertically against frame so base of foot has 8-9" minimum ground clearance when RV is loaded to its maximum GVWR (NOTE: the clearance of a raw rail is different than the clearance of a fully completed unit).
3. For all Leveleg installations, refer to the diagram with the correct configuration.

A. For 5K Direct Drive Landing Legs™,

- i. Attach mounting brackets to legs using 3/8" – 16 carriage bolts and nuts. Torque bolts to 18-20 ft-lbs. On each leg, position one bracket above and one below mounting tabs welded to landing leg housing.
- ii. Position legs against frame in a vertical position. Legs should not be more than 1/4" out of parallel with each other. Locate foot pads and lock pins for maximum ground clearance and to clear lower edge of trailer.
- iii. Mark mounting bracket location on trailer frame. Weld mounting bracket to trailer frame on both vertical sides and across either top or bottom. **DO NOT** weld edges that contact mounting tabs on landing legs.

NOTE: Due to different frame configurations, it may be necessary to weld angle bracket tubing to upper and/or lower part of frame to locate landing legs vertically and plumb.

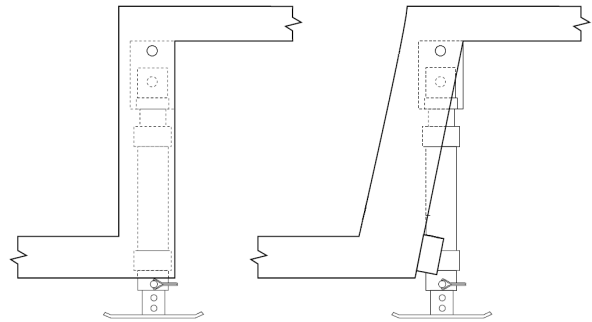

B. 7.5K Levelegs™. There are different ways

to mount the 7.5k Levelegs. The hat bracket shown below left attaches the Leveleg oriented to the front or rear of the RV, and the hat bracket shown below middle attaches the Leveleg oriented perpendicular to the frame.

- i. For bolt on assembly, attach the frame bracket to the frame using 4 sets of 1/2"-13 grade 5 nuts and bolts and 1/2" flat and locking washers. This bracket can also be welded to the frame on some units.
- ii. Fit the hat bracket around the Leveleg and attach to the frame bracket using 4 sets of 1/2" – 13 grade 5 bolts and 1/2" flat washers.

NOTE: The hat brackets used for the 7.5k Levelegs can be oriented in multiple ways to best fit the RV. The hat bracket can be rotated 180° to bolt the Leveleg higher or lower to the frame bracket. Also the top tab of the Leveleg can either fit through the slot of the hat bracket, or rest on the top of the hat bracket in order to offer more options for assembly. These options are illustrated in the figure below right.

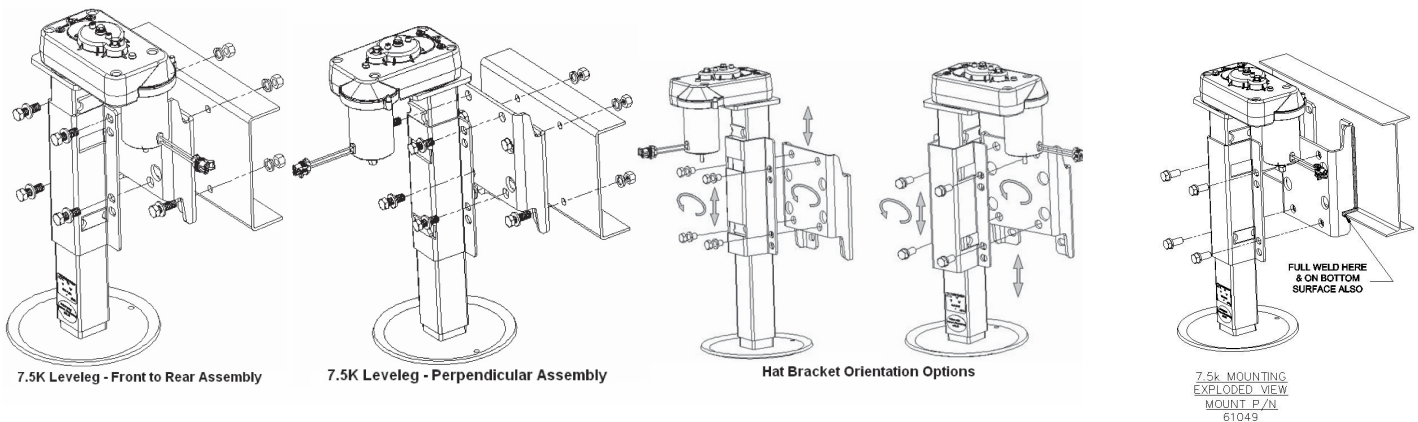

4. Lubricate the bolts and torque to 65 ft-lbs.

Dip Switch Configuration

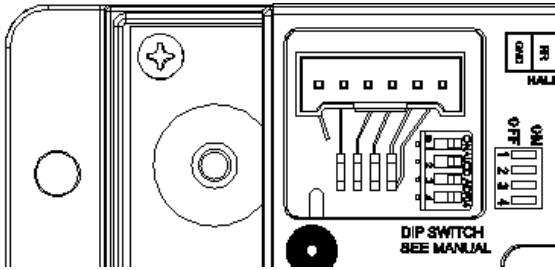

- In order to accommodate as many units as possible, there is a set of four small “dip switches” on the control board that must be configured. Refer to the following table and figure for the required configuration for your RV.

NOTE: If any of the blank configurations are used (noted by “DEAD POSITION) in the table below), the Controller will not work. In this case, the Control Pad Leveler position LEDs will flash up and down.

Configurations	Rear Levelers	Rear Levelers Stroke Length	Front Levelers	Front Levelers Stroke Length
0000	7.5K	15" of travel	5K Direct Drive	24" of travel
0001	7.5K	13" of travel	5K Direct Drive	24" of travel
0010	DEAD POSITION			
0011	DEAD POSITION			
0100	DEAD POSITION			
0101	DEAD POSITION			
0110	DEAD POSITION			
0111	DEAD POSITION			
1000	DEAD POSITION			
1001	DEAD POSITION			
1010	DEAD POSITION			
1011	DEAD POSITION			
1100	DEAD POSITION			
1101	DEAD POSITION			
1110	DEAD POSITION			
1111	DEAD POSITION			

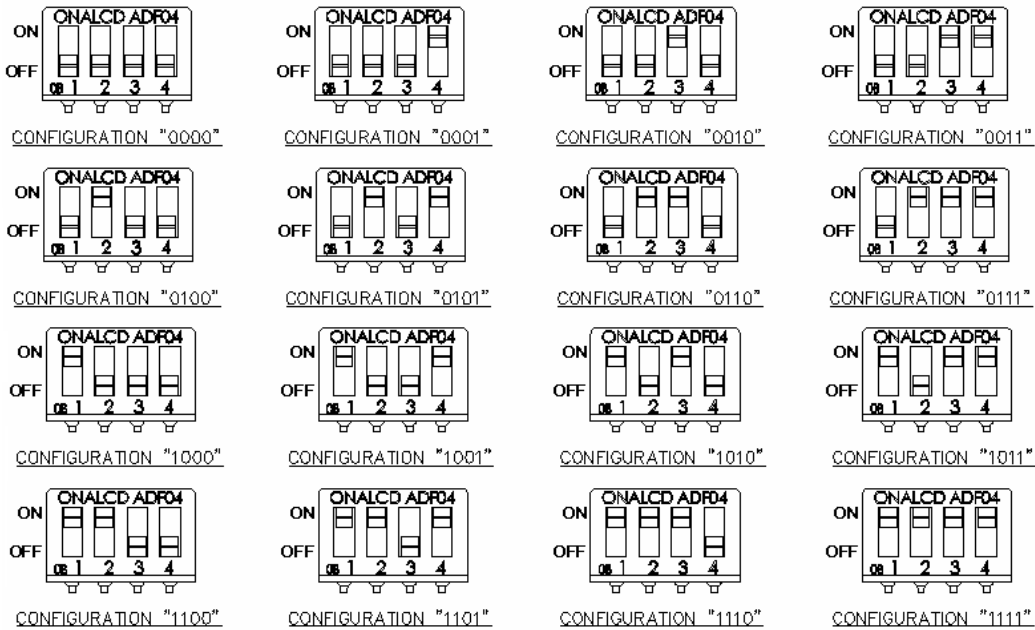

DIP SWITCH CONFIGURATIONS

NOTE: These switches MUST be configured correctly. Incorrect configuration can result in poor performance or damage to the system.

Controller Location

1. To optimize the effectiveness of the Controller, it should be mounted as close to the center of the RV as possible. There is an optimal zone and an acceptable zone to install the Controller as shown to the right. Any other place will compromise the operation of the Controller.
2. Install Controller in a clean, dry interior area protected from moisture. Use corner holes of unit to fasten base horizontally to mounting surface, using appropriate hardware for surface.
3. Install the AUTO POSITION Controller so the forward arrow points toward the front of the RV. The controller must be hung upside down to match the arrows on the side of the Controller, within 10° of horizontal level (parallel with mounting surface) as shown below. Sufficient space below the board must be provided for the wires to be connected.

NOTE: Any control board installed outside the acceptable area (defined to the right) will void warranty

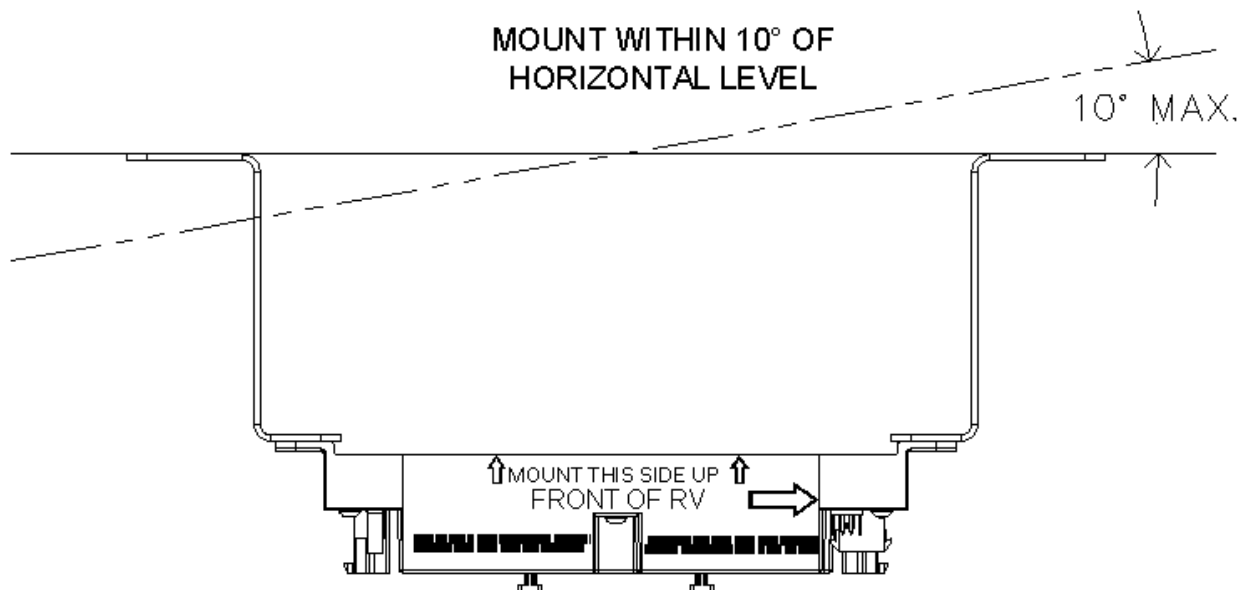
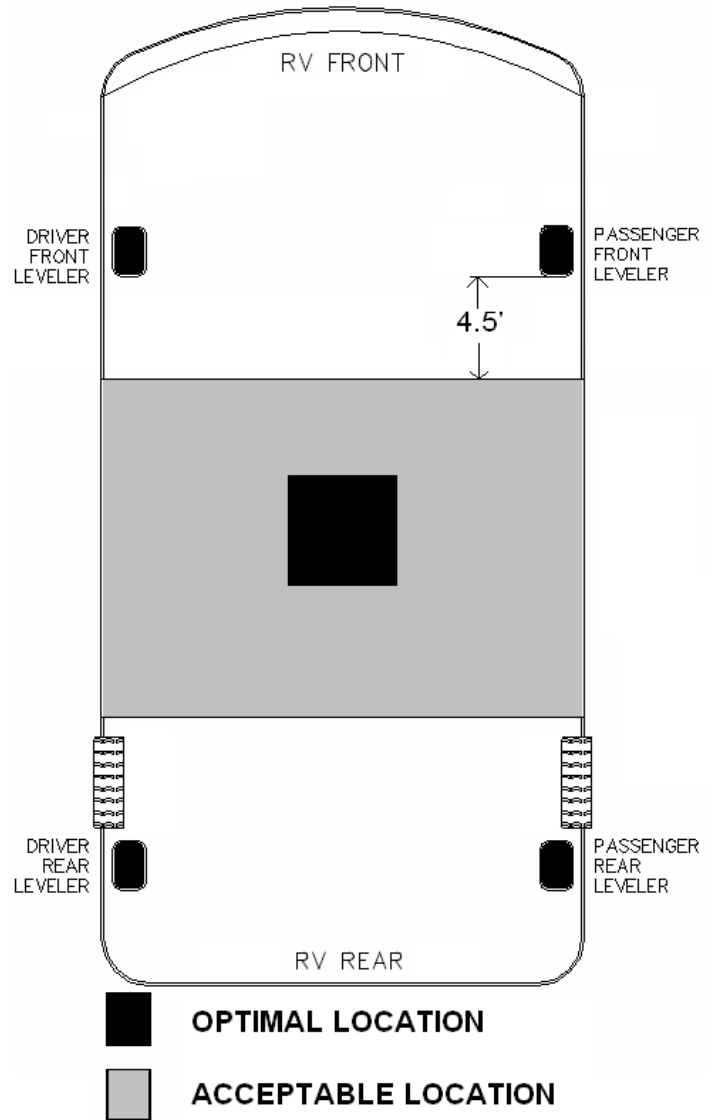



CONTROLLER WIRING

All information below pertains to the diagram on the page 10

NOTE: Atwood recommends using the Plug n' Play harness kit

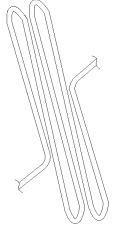
- If modifications to the harnesses must be made, please mimic the Atwood harnesses, and follow the guidelines provided by the manufacturer of the harness terminals. Be sure any wire crimps are strong enough as defined by the manufacturer. Poor connections can hurt system function. Refer to the wire harness index for the pin outs of each harness. Do not make any wires longer than specified below.
- For any extra wire after installing a harness, fold end to end (do not coil) and tie as shown. (see right)
- Atwood does not guarantee wiring functionality if wires are modified and/or new or different harnesses are made.



 **WARNING**
FIRE

- Secure 10 gauge leveler wires so that they do not run close to the nut on the motor.
- This nut rotates hundreds of revolutions per second, and could cut the insulation on the wires. This could cause sparks and fire, damage to the controller, leveler, and wire harness.

 **CAUTION**
PRODUCT DAMAGE

- Secure the wire harnesses in a safe area where they will not become damaged by heat, friction or moving parts.
- Failure to do so could cause damage to and hinder the function of the leveling system.

NOTE: For all wires, use strain relief clamps to reduce damage to the terminals.

Auto Position Control Pads

NOTE: Mount the control pad in a clean, dry, and lockable compartment.

1. Provide a space with the dimensions shown in the figure to the right for the control pad at desired location.

Note: Reference control pad when making cutout; there is tight clearance. Also to ensure the longevity of the product, mount keypad away from potential sources of moisture: windows, cup holders, etc.

2. Use the corner holes to fasten control pad to mounting surface using appropriate hardware for surface.
3. Connect control pad wire harness to control pad.
4. Route the control pad wire harness to controller and connect the two.
5. Fasten a strain relief clamp (not included) within 12" of the control pad. This is to prevent the wire harness connection from being damaged at the

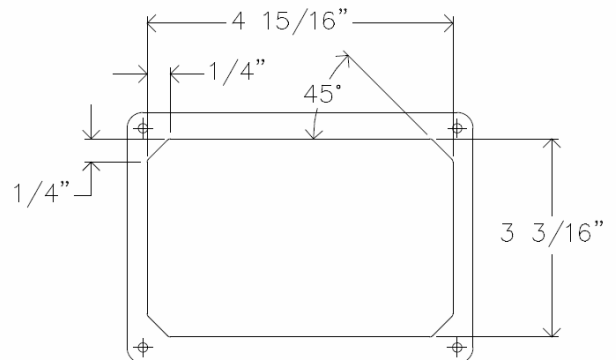

Control Pad Template

control pad.

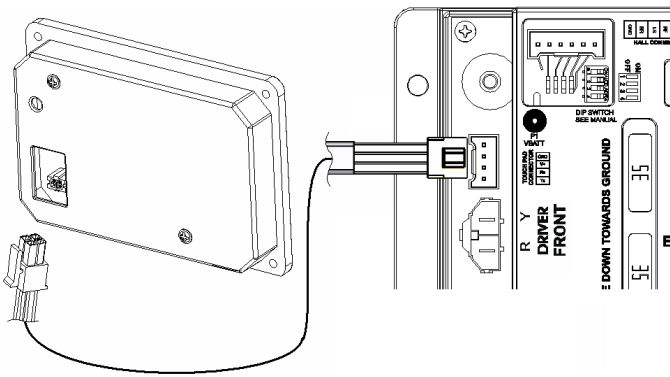

TOUCH PAD HARNESS

CONTROL PAD WIRE HARNESS			
PIN # (LEFT SIDE)	DESCRIPTION	COLOR	PIN # (RIGHT SIDE)
P1	DUT TX (Touch pad RX)	WHITE	CIRCUIT 1
P2	DUT RX (Touch pad TX)	GREEN	CIRCUIT 2
P3	POWER	RED	CIRCUIT 3
P4	GND	BLACK	CIRCUIT 4

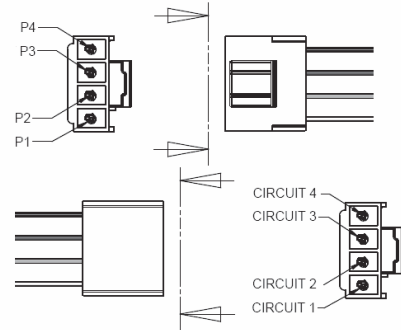

Signal Wire Harness / Activation Switch

NOTE: It is important for this harness to be plugged in after all other wires are installed.

1. Locate the activation switch next to the installed auto position control pad allowing clearance for both the controller and switch mounting surfaces. Provide a space with the dimensions shown in the figure to the right at desired location. **Note:** The clearance for the activation switch is not as tight.
2. Connect the 20 AWG wire ring terminal to the positive terminal (labeled P1 VBATT) on the controller along with the power connection (see "Power Connections" below) using the #10

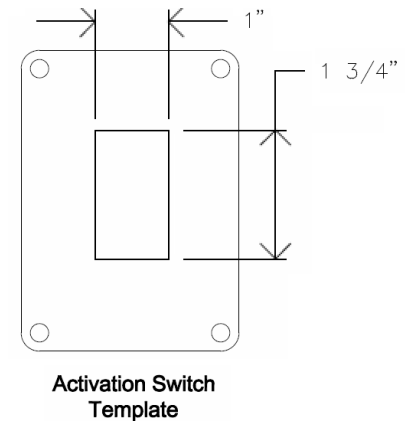

conductive washer, #10 lock conductive washer, and 10-32 conductive nut.

3. Plug in the harness (six pin terminal) to the corresponding connector on the control board.

Leveler Sensor Connections

- Use the 22 AWG connector (four harnesses feeding back to a single terminal at the control board) to connect the leveler signals to the control Board.
 1. Plug in the harness (six pin terminal) to the control board.
 2. Run the four harnesses from the control board compartment to each of the corresponding leveler locations.
 3. Plug in the four harnesses into the sensor terminal for the corresponding leveler motor.
 4. Secure the harnesses underneath the RV.

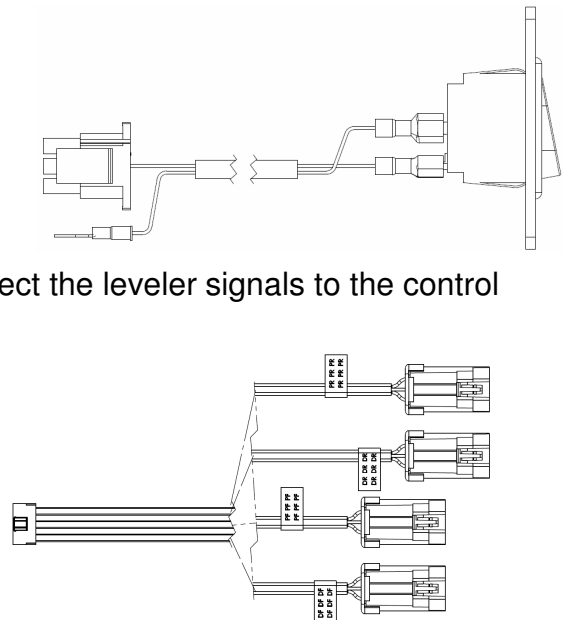

Leveler Power Connections

- Use the 10 AWG connectors (red and yellow wire) to connect the leveler motors to the control Board.

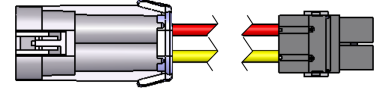

NOTE: Wires cannot run no longer than 20' to the front, and no longer than 30' to the rear.

1. Plug in the four harnesses into the power terminal on each of the corresponding leveler motors.
2. Run the four harnesses from each of the levelers to the control board compartment.
3. Secure the harnesses underneath the RV.
4. Plug in the harnesses to the control board. Verify that the correct harness is plugged into the corresponding terminal on the control board.

Power Connections

1. Connect the controller to the 12 VDC battery through the manual reset circuit breaker (see opposite page). This connection must be made within 18" of the battery or power source.
2. Connect the controller to the battery through 2 AWG wire.
3. Terminate 2 AWG wire power wire to controller through a 2 AWG ¼" ID ring terminal.
4. Attach ring terminal to controller with following components as shown on the opposite page: #10 conductive washer, #10 lock conductive washer, 10-32 conductive nut.

Note: Torque nut (See page 10) to 5-10 in/lbs. Excessive torque could damage the control board.

CAUTION PRODUCT DAMAGE

- Secure the wire harnesses in a safe area where they will not become damaged by heat, friction or moving parts.
- Failure to do so could cause damage to and hinder the function of the leveling system.

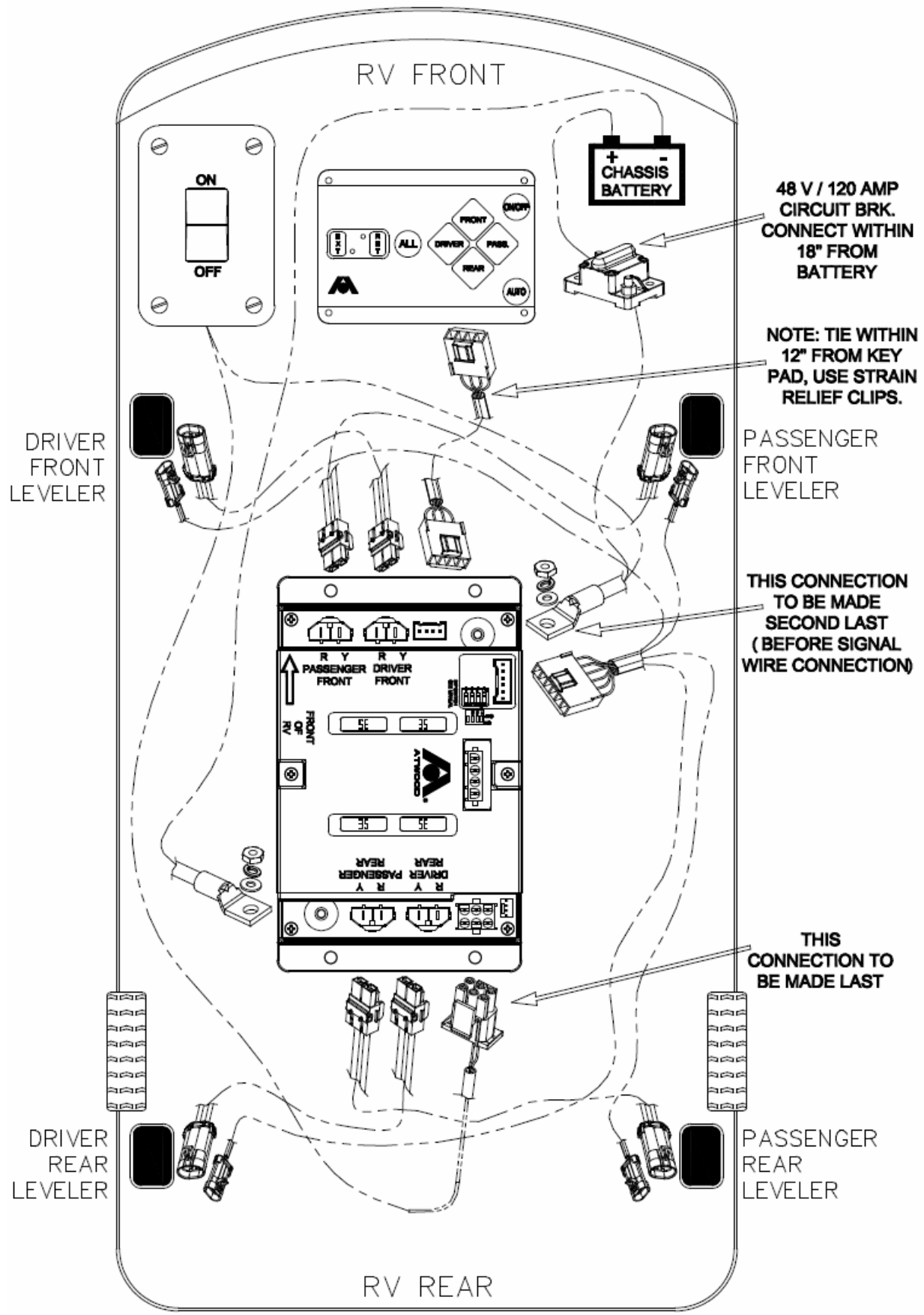

48 V / 120 AMP
CIRCUIT BRK.
CONNECT WITHIN
18" FROM
BATTERY

NOTE: TIE WITHIN
12" FROM KEY
PAD, USE STRAIN
RELIEF CLIPS.

PASSENGER
FRONT
LEVELER

THIS CONNECTION
TO BE MADE
SECOND LAST
(BEFORE SIGNAL
WIRE CONNECTION)

THIS
CONNECTION TO
BE MADE LAST

PASSENGER
REAR
LEVELER

DRIVER
FRONT
LEVELER

DRIVER
REAR
LEVELER

RV FRONT

RV REAR

OPERATION

BEFORE OPERATING THE LEVELERS



WARNING RV CAN TIP

- Levelers must be on firm solid ground or surface prior to operation. Soft/spongy ground may allow levelers to sink.
- Area below and around leveler must be clear of obstructions.
- Do not place blocks under the leveler for additional ground clearance.
- Operating the system on an excessive slope can be dangerous.
- Tires must stay on the ground at all times.

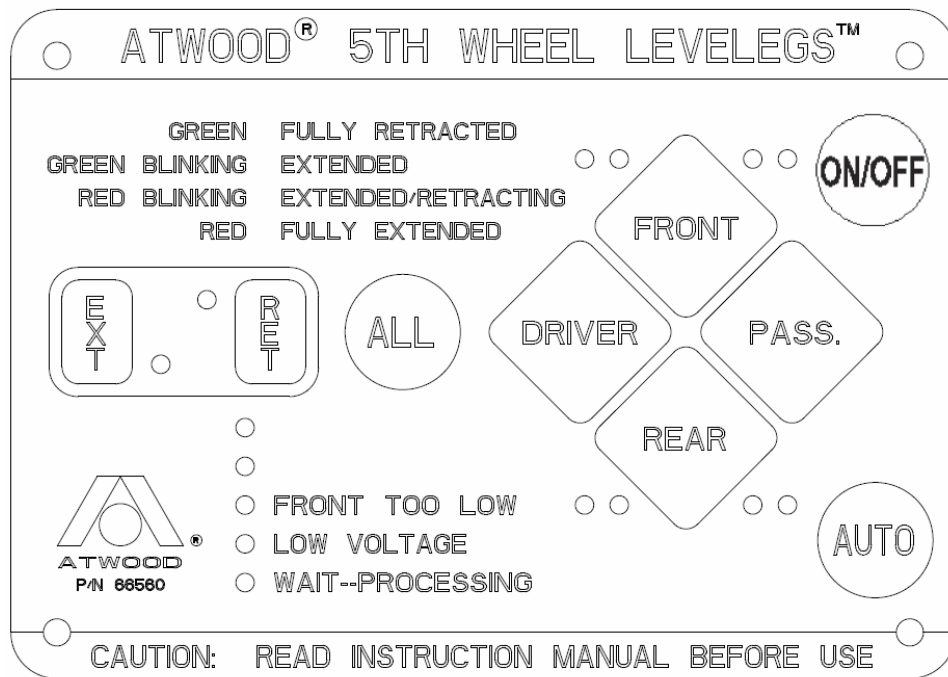

LEDs in all images will be represented in this format:

ON	●
OFF	○
BLINKING	⦿

Before operating the levelers, you must do the following:

1. Park the RV on as level a site as possible. Check for rocks, holes, or other obstructions. Warn all persons to stand clear of RV.

NOTE: The system will recognize excessive slope from front to rear only (greater than 4°). A slope of 4-6° will be identified by flashing the yellow EXT and RET LEDs on the keypad slowly. A slope greater than 6° will be identified by flashing the EXT and RET LEDs quickly. The AUTO feature will not function if the slope is greater than 6°.

2. It is recommended not to extend any slide outs until RV is level.



CONTROL BOARD INSTALLATION AND OPERATION

 **CAUTION**

PERSONAL INJURY/PRODUCT DAMAGE

- RV must be connected to the tow vehicle before performing a RET+ALL+FRONT function during normal operation, or before performing a RET+ALL function during installation or while in an error mode.
- Performing a RET+ALL function during installation or while in an error mode will simultaneously retract all levelers.
- Leveler extension or retraction in any auto function mode can be stopped by pressing any button on the key pad. The controller will reenter most functions after an emergency stop. If not, retract all levelers and begin function from that point.

TO SET HOME POSITION (ALL JACKS FULLY RETRACTED)

- If all Leveler lights are blinking green and red at the same time, HOME position must be programmed. To proceed, do the following while the RV is hooked to the tow vehicle:

NOTE: For instruction on how to manually hook RV to tow vehicle see page 14.

1. Switch Activation Switch to ON and Press the ON/OFF button to activate the system.
2. Press the EXT button and a directional button simultaneously to extend each pair of levelers at least 2" from fully retracted position.
3. Complete a successful ALL RETRACT as defined below;
 - i. Ensure slideout rooms are fully retracted (in their inboard position).
 - ii. Simultaneously press the RET and ALL buttons and hold for 5 seconds. All levelers will retract automatically to their fully retracted position. The leveler indicator LEDs will blink red when the levelers are moving.
 - iii. Once levelers are fully retracted, leveler indicator LEDs will be solid green. Visually verify that all levelers are fully retracted.
4. Press the ON/OFF button to turn key pad off and switch the Activation Switch OFF.

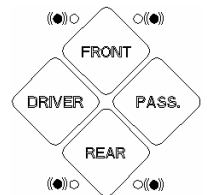
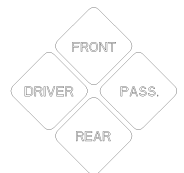

NOTE: If any of the levelers were not extended more than 1" before an ALL RETRACT was completed, the system will go into error signaled by the red and green LED's by the discrepant leveler flashing while an error tone is sounded. If an error occurs, repeat steps 1-3. If still unsuccessful, go to the troubleshooting section.

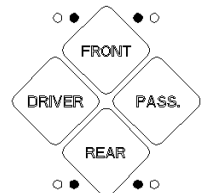

EMERGENCY STOP ANY LEVELER ACTIVITY

PRESS ANY BUTTON ON KEY PAD

TO SET AUTO POSITION (DEFINE LEVEL)

NOTE: This same process can be used to reprogram AUTO position. Set Home Position as described above before setting an AUTO position.

1. Switch Activation Switch to ON and Press the ON/OFF button to activate the system.
2. Simultaneous press EXT and ALL and FRONT buttons. This will extend the front landing gear to be in contact with the ground. LEDs for front levelers will be blinking green to indicate landing gear is down.
3. Manually set preferred hitch detachment position by pressing EXT and FRONT or RET and FRONT as needed.
4. Detach trailer lights, harness and hitch using manufacturer's suggested procedure. Move tow vehicle to safe position clear of RV.
5. Simultaneous press EXT and ALL and REAR buttons. This will extend the rear levelers to be in contact with the ground. LEDs for the rear levelers will be blinking green to indicate the rear levelers are down.

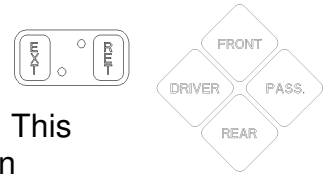
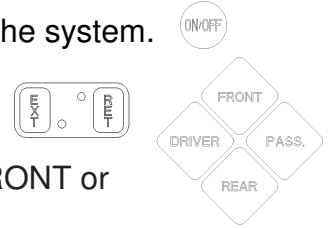

NOTE: Do not move around the inside of the RV while levelers are operating. This could throw off the balance of the RV and affect the system's ability to function correctly.

6. Simultaneously press and hold EXT and one of the directional buttons to raise the desired side of the RV: FRONT, REAR, DRIVER, PASS.
7. Repeat step 6 until the RV has reached the desired position.
8. If during this process any levelers are extended further than desired, any pair of levelers can be retracted to compensate. To perform this procedure, simultaneously press and hold RET and one of the directional buttons to lower the desired side of the RV: FRONT, REAR, DRIVER, PASS

NOTE: Levelers cannot be manually retracted past the point of initial ground contact.

9. Press the ON/OFF button to turn controls off.



10. Press EXT button 5 times.



11. Press RET button 5 times.

12. Unit will respond by blinking all LEDs slowly.

13. Press ALL button 3 times.

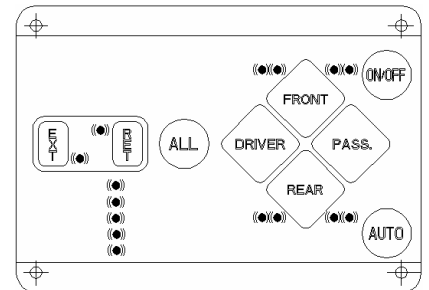

LEVELING MANUALLY

1. If the tow vehicle is attached perform steps 1 through 5 as described above in "TO SET AUTO POSITION (DEFINE LEVEL)". If all levelers are already in contact with the ground move to step 2 below.
2. Simultaneously press and hold EXT and one of the directional buttons to raise the desired side of the RV: FRONT, REAR, DRIVER, PASS.
3. Repeat step 2 until the RV has reached the desired position.
4. If during this process any levelers are extended further than desired, any pair of levelers can be retracted to compensate. To perform this procedure, simultaneously press and hold RET and one of the directional buttons to lower the desired side of the RV: FRONT, REAR, DRIVER, PASS

NOTE: Levelers cannot be manually retracted past the point of initial ground contact.

5. Press the ON/OFF button to turn key pad off and switch the Activation Switch OFF.



UNHOOKING FROM TOW VEHICLE AND LEVELING RV

NOTE: If any button is pressed during an auto sequence, the levelers will stop. The controller will reenter most functions after an emergency stop. If not, retract all levelers and begin function from that point.

If the Auto position is already set or programmed,

1. Switch Activation Switch to ON and Press the ON/OFF button to activate the system.
2. Simultaneous press EXT and ALL and FRONT buttons. This will extend the front landing gear to be in contact with the ground. LEDs for front levelers will be blinking green to indicate landing gear is down.
3. Manually set preferred hitch detachment position by pressing EXT and FRONT or RET and FRONT as needed.
4. Detach trailer lights, harness and hitch using manufacturer's suggested procedure. Move tow vehicle to safe position clear of RV.
5. Press AUTO to extend rear levelers and auto-position RV.
6. Process will take 2-3 minutes and wait LED will be lit. All leveler LEDs will blink green when process complete.
7. The system will check each Leveler to insure its foot is in contact with ground. During this time, the control board "WAIT" LED will be on.
8. The system will signal a successful or unsuccessful "auto position" sequence by:

Successful: The four green leveler position LEDs will illuminate in a rotating circle for 5 seconds before the keypad shuts off completely.

Unsuccessful: The four red leveler position LEDs will illuminate in a rotating circle for 5 minutes or until the ON/OFF button is pressed. If this occurs, see troubleshooting section under "AUTO POSITION DOES NOT LEVEL THE RV".

9. Press the ON/OFF button to turn key pad off and switch the Activation Switch OFF.

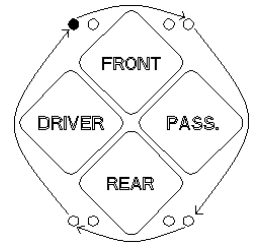
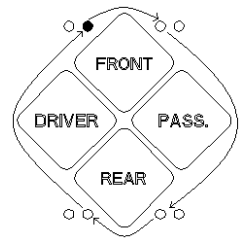
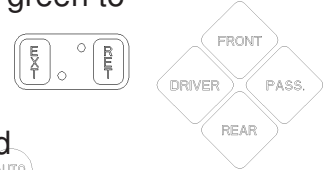

NOTE: Do not move around the inside of the RV while levelers are operating. This will reduce system effectiveness.

HOOKING UP TO TOW VEHICLE/ RETRACTION OF LEVELERS

If the home position has been programmed and levelers are on the ground;

1. Switch Activation Switch to ON and Press the ON/OFF button to activate the system.
2. If the rear levelers are retracted skip to step 3. Press RET and ALL and REAR to auto retract the rear levelers. LEDs for rear levelers will go to solid green to indicate levelers are fully retracted. A quick visual inspection should be done to check leveler ground clearance is proper for safe towing.
3. Press and hold EXT and FRONT or RET and FRONT to position king-pin/gooseneck to proper hitch connection height.
4. Follow hitch manufacturer's hook-up procedure to tow vehicle and connect trailer lights harness.
5. Once RV is safely connected to tow vehicle, press RET and ALL and FRONT to auto retract landing gear. LEDs will go to solid green to indicate landing gear is fully retracted. A quick visual check of landing gear ground clearance should be done to insure safe towing.
6. Press the ON/OFF button to turn key pad off and switch the Activation Switch OFF.

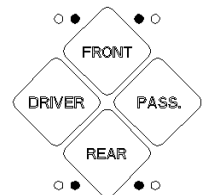
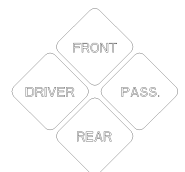

If the home position has not been programmed or while in error mode and all levelers are retracted;

1. Switch Activation Switch to ON and Press the ON/OFF button to activate the system.
2. Press the EXT button and a directional button simultaneously to extend each pair of levelers at least 2" from fully retracted position.
3. Simultaneously press and hold EXT and FRONT or RET and FRONT to position king pin/gooseneck to proper hitch connection height.
4. Follow hitch manufacturer's hook-up procedure to tow vehicle and connect trailer lights harness.
5. Once RV is safely connected to tow vehicle, press and hold RET and ALL for 5 seconds to auto retract all levelers. LEDs will go to solid green to indicate levelers are fully retracted. A quick visual check of ground clearance should be done to insure safe towing.
6. Press the ON/OFF button to turn key pad off and switch the Activation Switch OFF.

If the home position has not been programmed or while in error mode and all levelers are on the ground;

1. Switch Activation Switch to ON and Press the ON/OFF button to activate the system.
2. Simultaneously press and hold RET and REAR to bring the rear levelers off the ground. There needs to be at least 2" of ground clearance.
3. Simultaneously press and hold EXT and FRONT or RET and FRONT to position king pin/gooseneck to proper hitch connection height.
4. Follow hitch manufacturer's hook-up procedure to tow vehicle and connect trailer lights harness.
5. Once RV is safely connected to tow vehicle, press and hold RET and ALL for 5 seconds to auto retract all levelers. LEDs will go to solid green to indicate landing gear is fully retracted. A quick visual check of landing gear ground clearance should be done to insure safe towing.
6. Press the ON/OFF button to turn key pad off and switch the Activation Switch OFF.

NOTE: If any of the levelers were not extended more than 1" before an ALL RETRACT was completed, the system will go into error signaled by the red and green LEDs by the discrepant leveler flashing while an error tone is sounded. If an error occurs, repeat steps 1-3. If still unsuccessful, go to the troubleshooting section.

These controls have the following features to facilitate leveling:

- **OPTIMIZING STROKE** A mathematical calculation using the percentage of currently available stroke determines when to extend and when to retract levelers during the AUTO feature to maximize use of total stroke, enabling the system to level more efficiently and effectively.
- **FULL EXTENSION** If a leveler is fully extended, its corresponding LED will indicate this and further operation of that pair of levelers in the extend direction is prevented. If the switch is held on, the second leveler of the pair will operate with its alternate pair partner leveler. (i.e., if the front two levelers are extending and the left front leveler becomes fully extended, the right front leveler will continue to operate and the right rear leveler will start to extend.) This is to keep the frame from twisting.
- **LOAD COMPENSATION** If one leveler becomes disproportionately more loaded than its pair partner, power will shut off to the first leveler. The second leveler will continue to operate until the load is more balanced between the pair of levelers. Power to the first leveler will then resume.
- **KISS THE GROUND** After AUTO positioning is complete, the system will briefly run each leveler one at a time to confirm contact with the ground and improve RV stability.

SYSTEM PROTECTION FEATURES

Nine Cycle Maximum

- The controls will shut off for about 15 minutes any time nine (9) RET ALL commands are completed in less than 30 minutes.
- When this occurs, all vertical signal lights blink off and on.
- This sequence can be overruled by turning the activation switch OFF and disconnecting power from the control board for one minute, then reconnect power and turn activation switch ON.

Low Voltage Protection

- The system will not allow any operation to begin unless battery voltage is above 12.5 VDC. The low voltage LED will flash to indicate this.
- If the voltage falls below 10.0 VDC during any operation, leveler operation will cease and the low voltage LED will flash.
- Controls will be inoperable until battery voltage climbs above 12.5 VDC, at which time leveling functions will resume.

Manual Override Front Landing Gear

- To Manually Extend or Retract a front Leveler, use either the manual crank handles assembly or the drill bit crank adapter.
- Rotate drive shaft counter clockwise to extend the 5K Direct Drive leveler.
 - A. It takes approximately 7 revolutions of drive shaft to extend/retract leveler 1”.

Manual Override Rear Levelers

- To Manually Extend or Retract a rear Leveler, use a ½” socket on Drive Nut on the end of the motor.
- Rotate nut counter clockwise (looking from bottom end of nut) to extend the 7.5K or 10K levelers.
 - A. It takes approximately 500 revolutions of nut to extend/retract leveler 1”.

NOTE: If levelers are ever operated in this way, HOME position must be reset. To do this, refer to the TROUBLESHOOTING section under “RET ALL DOES NOT FULLY RETRACT LEVELERS”.

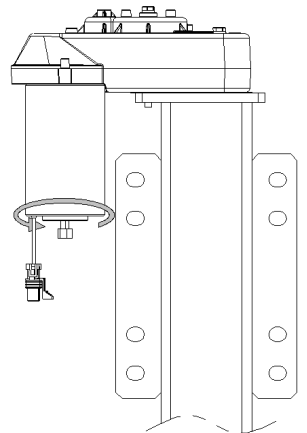
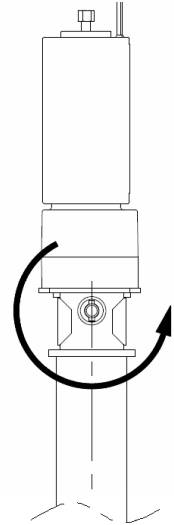

CAUTION

PERSONAL INJURY/PRODUCT DAMAGE

- Battery operated drills, 9.6V to 18V, are powerful. Hold drill with both hands to protect your wrist. Keep loose clothing and body parts away from drill as the reaction torque from the drill may cause it to kick back.
- Refer to your drill manufacturer’s operation manual.
- Do not over extend or over retract levelers. Each leveler has built in stops. Excessive force applied against the stops will cause damage.
- When manually overriding the leveler do not use pneumatic tools to operate any leveler. They can over-extend or over-retract the leveler.
- If the motor will not extend/retract the leveler and the motor is making a ratcheting sound (clutch slipping), do not use the manual override. Immediately contact an Atwood Service Center and have leveler replaced. Do not use the leveler until replaced.

MAINTENANCE

1. Internal parts of leveler are permanently lubricated at the factory and do not require any further lubrication.
2. If it is not possible to get levelers to operate freely, replace leveler.
3. Should problems or questions arise, contact your dealer, camper manufacturer, or Atwood Consumer Service Department 1-866-869-3118.

ATWOOD LIMITED WARRANTY

Atwood Mobile Products warrants to the original retail owner and subject to the below mentioned conditions, that this product will be free of defects in material or workmanship for a period of two years from the original date of purchase. Atwood's liability hereunder is limited to the replacement of the product, repair of the product, or replacement of the product with a reconditioned product at the discretion of the manufacturer. This warranty is void if the product has been damaged by accident, unreasonable use, neglect, tampering or other causes not arising from defects in material or workmanship. This warranty extends to the original owner of the product only and is subject to the following conditions:

1. For two (2) years commencing with the date of purchase of the original owner from the Original Equipment Manufacturer (OEM), and for one (1) year for aftermarket installation, Atwood will provide the replacement or repair of any Hardware System and Components that are found to be defective by Atwood in material or workmanship. All replacement components must be replaced with Atwood original parts or the warranty will be void.
2. **In the event of a warranty claim, the original owner must contact the Atwood Consumer Service Department, 1120 North Main, Elkhart, IN 46514 USA. Phone: (574) 264-2131.** Warranty Claim Service must be performed as approved by the Atwood Consumer Service Department. Warranty replacement components will be furnished freight prepaid. The replaced warranty products or parts become the property of Atwood Mobile Products and must be returned to the Atwood Consumer Service Department freight prepaid, unless prior arrangements have been made.
3. This limited warrant is valid only when the product is applied, installed, maintained and operated in accordance with this Atwood Installation Maintenance and Operating Manual. Any deviation from these recommended specifications must be approved in writing by Atwood.
4. ANY IMPLIED WARRANTIES arising by way of State Law, including any implied warranty of merchantability and any implied warranty of fitness for a particular purpose are limited in duration to the term of this Limited Warranty. Atwood makes no further warranty of any nature beyond this Limited Warranty. No person has authority to enlarge, amend or modify this Limited Warranty.
5. Any action to enforce this warranty shall not be commenced more than six (6) months after the expiration of this warranty.

11.8.10



1120 North Main Street • Elkhart, IN 46514
PHONE: 574-264-2131 • FAX: 574-206-9713
INTERNET: <http://www.atwoodmobile.com>

LEVELEGS™ w/SENSOR TECHNOLOGY FOR TOWABLE RV'S

TROUBLE SHOOTING GUIDE

ENGLISH

Effective 6/27/11

Rev A

This guide is only intended for use on Atwood products by service technicians who have successfully completed Atwood training. This guide should be used in conjunction with the appropriate Instruction Manual provided with the product and any applicable Industry Standards. This is not intended to be a complete list. Please direct questions concerning service of Atwood products to 1-866-869-3118 before proceeding.



WARNING

PERSONAL INJURY AND/OR PRODUCT DAMAGE

- If any of the following conditions develop, the RV must not be used until proper corrective action is taken.

CAUSE WITH SOLUTIONS

NOTE: The noise of the levelers will vary with the different loading situations of the RV. A change in noise alone is not an indicator of an issue.

KEY PAD WILL NOT TURN ON

- No power to key pad
 1. Insure Activation Switch is flipped to the ON position.
 2. Check wiring between keypad and control board.
 3. Turn off Activation Switch, disconnect power on the control board (labeled P1 VBATT, towards the front of the RV) for one minute and then reconnect. Make sure to connect power before turning on Activation Switch.

SCROLLING LIGHTS ON KEYPAD

- Communication between keypad and control board lost.
Check wiring between keypad and control board.

RED AND GREEN LIGHTS COME ON FOR LEVELERS DURING INSTALL PROCEDURE

- Incorrect wiring
 1. Press EXT and the two directional buttons (e.g. DRIVE and FRONT) that make up the position of that leveler. If the leveler moves for about 0.25-0.5 seconds and then stops, the wiring could be incorrect.
 - i. Check that the correct leveler moves when EXT and the two directional buttons that make up the position of that leveler are pressed.
 2. Check that the power wires for the levelers are connected to the correct terminals on the control board.
 3. Check that all of the SENSOR CONNECTOR wires are connected to the corresponding motor at each of the leveler locations.

LEVELER CONTINUES TO “CLUTCH”

- Leveler replaced or operated separate from control pad (manually operating nut / drive shaft or supplying direct power to the leveler)
- If the system does not beep an “error mode”
 1. Put system in error mode by disconnecting one leveler from power and pressing either RET or EXT and FRONT or REAR for the corresponding leveler.

NOTE: The attempted operation must require the disconnected leveler to function through the board.

2. Reconnect leveler to power.
3. Confirm all levelers are extended a minimum of 2” from their fully retracted position. If necessary manually extend all levelers by either:
 - a. Simultaneously pressing the EXT button and the two directional buttons (e.g. DRIVE and FRONT) that make up the position of a single leveler.
 - b. Simultaneously pressing the EXT button and one directional button in order to move the two levelers on that side.

NOTE: Levelers will stop moving if a button is released.

4. Listen to insure all levelers move when manually activated.
 5. Hook the RV to the tow vehicle.
 6. Press RET and ALL to retract all levelers.
- If the system beeps an “error mode”
 1. Press ON/OFF button. This will shut the warning alarm off and turn the system back on.
 2. Make sure all levelers are at least 2” extended from full retraction. Manually extend the levelers as shown in step 3 above if they are not.
 3. Continue from step 4 above. Wait until all four leveler indicator LEDs are solid green. The system is now out of error mode and ready for normal operations.

RED AND GREEN LIGHTS COME ON FOR A SPECIFIC LEVELER LOCATION

- Loss of power or signal to leveler
 1. Manually extend the individual leveler by holding down the EXT button and the two directional buttons that make up the location of that leveler. Listen to insure all levelers move when manually activated.
 2. If leveler moves continue to step 3. If leveler does not move check the fuse for that location at the control board. Replace fuse with Littelfuse Series 299 MAXI® Slo-Bl® 32VDC, 35 ampere Automotive Blade Fuse or equivalent.
 3. Hook the RV to the tow vehicle.
 4. Press RET and ALL to retract all levelers.
 5. If levelers do not move, inspect leveler power wiring at levelers and at control board to insure proper connection.
 6. If levelers briefly move (0.5 seconds) and then stop, inspect leveler sensor wiring at levelers (smaller wires) at the motor and at the control board to insure proper connection.

ALL VERTICAL SIGNAL LIGHTS BLINK ON AND OFF

- Nine cycle protection: If nine RET and ALL sequences are completed within 30 minutes, the system will lock out for 15 minutes. To resolve, either:
 - a. Wait 15 minutes until the system becomes unlocked, or
 - b. Turn the activation switch off and disconnect power from the control board for one minute, then reconnect power and turn activation switch ON.

KEY PAD SIGNAL IS INTERMITTENT

- Check the connection of the activation switch at both the power connection, and six pin connector.

LEVELERS WILL NOT MOVE

- No power or signal to levelers
 1. Check the circuit breaker and reset if necessary.
 2. Insure the Activation Switch is in the ON position.
 3. If emergency stop was activated by pressing any keypad button during an AUTO function (the four keypad lights should be blinking green) and the rear levelers are extended, press RET and ALL and hold for 5 seconds. If rear levelers are fully retracted skip to step 3.
 4. Manually set preferred hitch detachment position by pressing EXT and FRONT or RET and FRONT as needed.
 5. Connect the RV to the truck and press RET and ALL and hold for 5 seconds to reset legs.
 6. The system will never let you manually retract levelers past the point where they originally touched the ground. Try manually extending pairs of levelers by pressing EXT and then the directional button of the side of the RV that needs to be lifted.
- Emergency stop of AUTO sequence
 1. If any button was pressed during the Auto Position sequence, movement of all levelers will immediately stop
 2. To resolve, continue from step 2 above.

AUTO POSITION DOES NOT LEVEL THE RV

- If the keypad gives a signal that an unsuccessful level sequence was completed (rotating red circle of lights),
 1. Turn off the keypad by pressing the ON/OFF button. Press again to turn the keypad back on. If one of the lights is solid red, a leveler has reached its limit, meaning:
 2. The ground is too uneven. Find a more level spot and try again. The EXT and RET lights will blink together if the ground is too sloped.
- If the keypad gives a signal that a successful level sequence was completed (rotating green circle of lights for 5 seconds);, but the RV is still not level,:
 1. The last position in memory was not level. Leveler System always returns to the position in memory.
 2. Press the AUTO button again. If no levelers move, then:
 3. The control board must be mounted horizontally, on a solid fixed surface and can not be more than 10 degrees out of level.
 4. Manually set RV to desired position and program position into memory, following the steps on page 13.

NO LEVELERS MOVE WHEN AUTO IS PRESSED

- An Auto Position is not set (keypad lights will blink)
Set the Auto Position, referring to page 13.
- Excessive tilt
 1. The yellow EXT and RET lights will blink together if the RV is located on sufficiently sloped ground.
 - i. The EXT and RET lights will blink slowly as a warning if the RV is more than 4° out of level
 - ii. The EXT and RET lights will blink quickly if the RV is more than 6° out of level. The system will not run an AUTO sequence in this case.
 2. If the EXT and RET lights blink quickly, the system will not run an AUTO sequence. To proceed, either:
 - i. Move the unit to more level ground and try again.
 - ii. Press EXT and ALL and FRONT to get the front levelers on the ground. Once grounded press EXT and ALL and REAR to ground the rear levelers, then manually level the unit as defined on page 13.

PANEL LIGHTS BLINK “ON” AND “OFF”

- An Auto Position is not set
Set the Auto Position, referring to page 13.

FALSE RET (FULL RETRACTION) ERROR MODE

- Every 50 cycles, the levelers will relearn where the fully retracted position is. If this is more than 4” different than before, the following occurs:
 1. Warning alarm will sound.
 2. Power is removed from the control box disabling normal operations. (This is done to encourage operator to do a visual inspection of levelers prior to further leveling operations.)
 3. The red and green LEDs for the particular leveler will blink on and off to indicate the system is in an error mode.
- To proceed,
 1. Press ON/OFF. This will shut the warning alarm off.
 2. Visually inspect the leveler.
 3. If it is required, activate levelers to correct problem. Simultaneously press the EXT or RET button and the two directional buttons (e.g. DRIVE and FRONT) that make up the position of leveler of the lit LEDs. In error mode, any leveler can be activated in this manner.
 4. Hookup the RV to the tow vehicle as described on page 14 for the description that matches the current system situation.
 5. Complete an ALL RETRACT operation as described on page 12 and system is now out of error mode and ready for normal operations. Make sure that all levelers are at least 2” extended before retracting.

RET ALL DOES NOT FULLY RETRACT LEVELERS

- If all leveler indicator lights are solid green, reprogramming the HOME position is necessary. To do this:
 1. Simultaneously press the EXT and ALL and FRONT buttons. The leveler indicator lights will all blink green when this is finished.
 2. Disconnect power or signal to one of the rear levelers.
 3. Simultaneously press the EXT and ALL and REAR buttons. This will send the disconnected leveler into error. The leveler indicator lights will blink green and red, and an alarm will go off.
 4. Press ON/OFF to turn off the alarm and to turn on the keypad.
 5. Reconnect the leveler to power/signal.
 6. Hookup the RV to the tow vehicle as described on page 14.
 7. Simultaneously press the RET and ALL and hold for 5 seconds. Leveler indicator lights will blink red while moving. Wait until all leveler indicator lights are solid green. You may hear a brief clutch from each leveler. The new HOME positions should now be programmed.
 8. Visually confirm that the levelers have fully retracted.
- If any leveler indicator lights are blinking green, this means there was an emergency stop during the ALL RETRACT process. To proceed:
 1. If a rear leveler light is blinking simultaneously press RET and ALL and REAR.
 2. If a front leveler light is blinking hookup the RV to the tow vehicle as described on page 13.
 3. Simultaneously press RET and ALL and FRONT. Leveler indicator lights will blink red while moving. Wait until all leveler indicator lights are solid green.
 4. Visually confirm that the levelers have fully retracted.

SYSTEM IS BEHAVING STRANGELY

- If levelers commonly clutch in extend or do not extend as far as they should be able to, the Dip Switches may have been configured incorrectly.
- Refer to page 5 and compare the unit’s leveling system with the dip-switch configurations

Harness Index

Sensor Harness

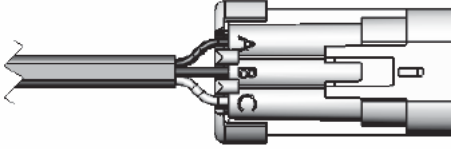

PIN #	COLOR	SIGNAL
A	BLACK	GROUND
B	RED	POWER
C	WHITE	PULSE

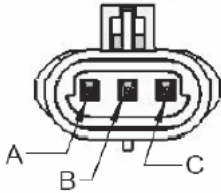

SENSOR CONNECTOR

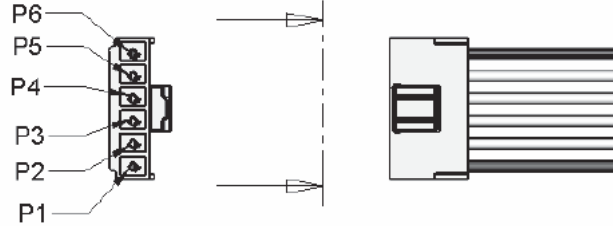

PIN #	DESCRIPTION	COLOR
P1	POWER	RED - SAME ON ALL
P2	DRIVER FRONT	WHITE WITH (BLUE) TRACE COLOR
P3	PASSENGER FRONT	WHITE WITH (RED) TRACE COLOR
P4	DRIVER REAR	WHITE WITH (GREEN) TRACE COLOR
P5	PASSENGER REAR	WHITE WITH (BROWN) TRACE COLOR
P6	GND	BLACK - SAME ON ALL

TOUCH PAD HARNESS

CONTROL PAD WIRE HARNESS			
PIN # (LEFT SIDE)	DESCRIPTION	COLOR	PIN # (RIGHT SIDE)
P1	DUT TX (Touch pad RX)	WHITE	CIRCUIT 1
P2	DUT RX (Touch pad TX)	GREEN	CIRCUIT 2
P3	POWER	RED	CIRCUIT 3
P4	GND	BLACK	CIRCUIT 4

